sailQube

Rigging manual SailQube School & Race



ZIM SAILING



Rigging manual SailQube School & Race

Congratulations on the purchase of your SailQube!

Please take the time to read through this manual in order to familiarise yourself with your SailQube. If you have any further outstanding questions, please contact your dealer.

This manual is not a guide to sailing your SailQube and it should not be considered suitable for the task of learning to sail a boat.



	<i>Page number</i>
1. SailQube Component Parts	4
2. Glossary	5
3. Useful Knots	6
4. SailQube Assembly Tools Required	7
5. Safety	7
6. Assembling & Rigging Your SailQube	9
1. Sprit Halyard Fitment	9
2. School Sail Fitment (SailQube School – SQS)	9
3. Race Sail Fitment (SailQube Race – SQR)	10
4. Boom Vang Fitment	11
5. Outhaul Fitment	11
6. Mainsheet Bridle Fitment	11
7. Stepping the Mast	12
8. Sprit Fitment	13
9. Rigging The 3:1 Mainsheet (SailQube School – SQS)	13
10. 4:1 Mainsheet Ratchet Block Fitment (SailQube Race – SQR)	14
11. Rigging The 4:1 Mainsheet (SailQube Race – SQR)	15
12. Rigging The Painter	16
13. Rudder Assembly	16
14. Rudder Fitment	17
15. Dagger-board Fitment	17
16. Toe-Strap Configuration	18
17. Other Hints and Tips	19
7. Cleaning	20
8. Service	20
9. Storage & Transport	21
10. On The Water Towing	21

1. SailQube Component Parts

Before proceeding further, please check your SailQube includes the following component parts:

SailQube School Complete (Part Code – SQS)

1. SailQube Hull Complete (Part Code – SQH)
2. School Spars – Mast, Boom & Sprit
3. Varnished Wooden Foils – Dagger-board, Rudder, Tiller & Extension
4. School Sail
5. Line/Block Pack

SailQube Race Complete (Part Code – SQR)

1. SailQube Hull Complete (Part Code – SQH)
2. Race Silver Spars – Mast, Boom & Sprit
3. Varnished Wooden Foils – Dagger-board, Rudder, Tiller & Extension
4. Race Sail with Battens, Corner and Sail Ties
5. 4:1 Mainsheet Ratchet Block, Stainless Deck Fairlead, X2 Stainless Steel Fasteners (m/screw, pozi pan, M5x10mm)
6. Line/Block Pack

The contents of the Line/Block Pack (common to SailQube School – SQS and SailQube Race - SQR) are as follows:

- a. Painter - (8mm x 7000mm Blue/Purple)
- b. Mainsheet - (8mm x 7000mm Blue/Purple)
- c. Sprit Halyard - (5mm x 1600mm Blue/Yellow)
- d. Boom Vang - (6mm x 900mm Blue/Yellow)
- e. Outhaul - (4mm x 1200mm Blue/Yellow)
- f. Boom Bridle (3mm x 500mm Blue/Yellow) with 25mm/1" Stainless Steel Ring
- g. Mainsheet Fiddle/Becket Block With Trigger Shackle
- h. Mainsheet Fiddle/Becket Block With Screw Shackle



Mainsheet SQS



Mainsheet SQR

2. Glossary

Bow:

Stern: Front of the boat

Transom: Back of the boat

Fore: Back of the boat

Aft: Forward

Rearward

Clew:

Tack: Back lower corner of a sail

Head: Forward lower corner of sail

Luff: Foot: Top corner of sail

Leech: Forward edge of the sail

Bottom edge of the sail

Burgee: Rear edge of the sail

Batten: Wind direction indicator
(usually a small flag)

Mast: A thin stiffening strip in
the sail to support the leech

Boom: Main vertical spar
supporting the rig/sails

Sheet: Spar at the Bottom of the
mainsail

Gunwale: Rope for controlling the

Gudgeon: inward/outward position of the sail

Pintle: The outermost edge of the boat

Female fitting on the transom used to hang & locate the rudder
Corresponding male fitting on the rudder used to hang & locate the rudder

Cunningham: Purchase system for tightening the forward edge/luff of the sail

Vang: Purchase system for tightening the rear edge/leech of the sail

Outhaul: Purchase system for tightening the bottom edge/foot of the sail

Mast Heel: Bottom edge/foot of the mast

Mast Step: Adjustable/integral cup in the boat where the mast heel/foot is located

Rudder: Blade and attachments used for steering the boat

Dagger-Board: Blade used to inhibit sideways slippage (leeway) and improve stability.

Painter: Rope exiting through the bow/front of the boat used for leading/
towing or tying the boat to a jetty or buoy.

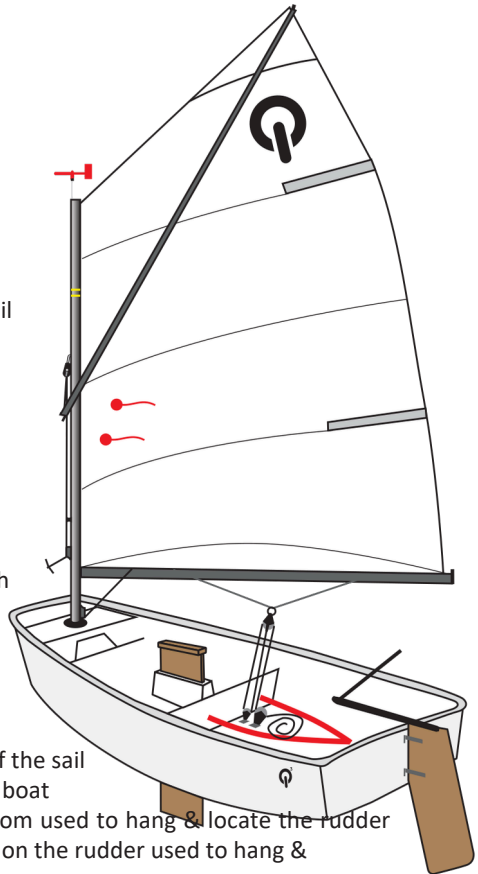

3. Useful Knots

Bowline Loop:

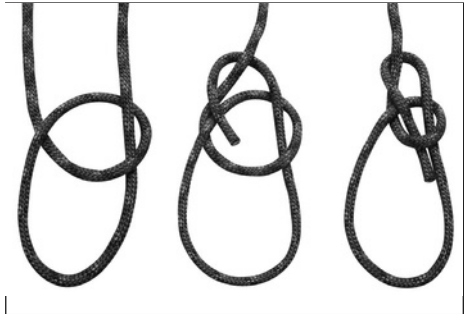
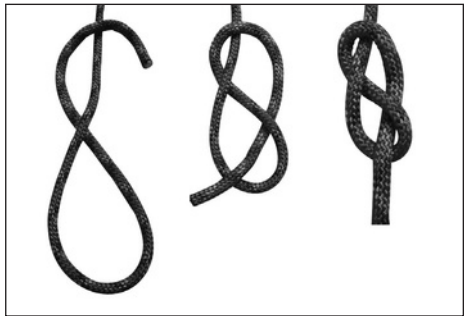
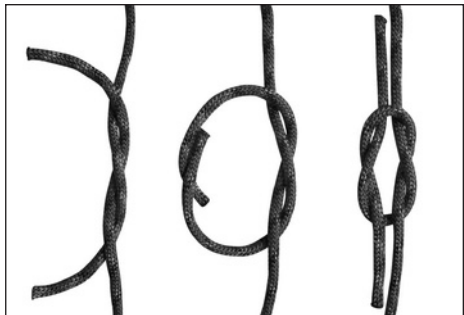

Figure of 8 Stopper Knot:



Square Knot:



Double overhand stopper knot:



4. SailQube Assembly Tools Required

- 1 x medium size flat blade screwdriver
- 1 x medium size pozi blade screwdriver (PZ2 ideally)
- 1 x 7mm or 9/32" spanner or adjustable spanner
-

5. Safety

Your SailQube has two hatches and one drain bung, these **MUST** all be checked to ensure tightness and correct fit prior to sailing.

The hatches are located either side of the mast deck plate. The drain bung is located on the lower starboard/right side of the transom.



(figure 1)

(figure 1)

Check all are closed securely by turning it in a clockwise direction until hand tight.

Before You Go Sailing:

- Check you are wearing suitable clothing and safety equipment for the conditions and time of year.
- Always wear a buoyancy aid or life jacket
- Make sure a third party knows where you are sailing and how many there are of you.
- Check the weather forecast
- Check the time of high and low tides if applicable.
- Seek advice of local conditions if sailing in a new area.
- Always check the condition of your craft before setting off.
- Check for overhead cables when rigging, launching and recovering.



Launching:

- Raise the rig with the boat facing into the wind.
- Launch the boat using the appropriate launching trolley.
- Take the boat into the water with the bow facing into the wind.
- Ensure that there is enough water to float the boat off the trolley.
- When there is enough water below you, lower the centreboard and rudder fully.
- The rudder and the centreboard should always be raised before coming ashore.

On The Water:

- Conform to the sailing rules of the road.
- Look out for changing weather conditions.
- Never sail beyond your ability or that of your crew.
- Understand and be competent in your sailing skills and righting techniques.

6. Assembling & Rigging Your SailQube

1. Sprit Halyard Fitment

Take the sprit halyard rope and tie a 25mm/1" diameter bowline loop in one end.

(figure 2)



(figure 2)

Thread the other end of the sprit halyard rope:

- Through the block (pulley) on the forward face of the mast. (Traveling in a downward direction)

(figure 3)

- Through the cleat on the lower forward face of the mast. (Traveling in a downward direction)

- Tie a 100mm/4" diameter bowline loop in the tail end to use as a handle.

(figure 4)



(figure 3)

2. School Sail Fitment (SailQube School – SQS)

- Slide the mast in to the luff sleeve on the leading/forward edge of the sail. (Bare unfitted end first travelling in an upward direction)

(figure 5)

- Slide the boom through the two webbing straps on the foot/lower edge of the sail. (Boom outboard end cap first traveling in an aft/rearward direction)

(figure 6)

- Clip the boom gooseneck/claw clamp fitting to the mast. (Ensure the boom fitted hardware faces upwards towards the foot of the sail)

(figure 7)



(figure 4)



(figure 6)



(figure 7)

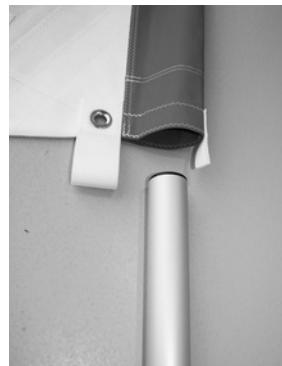

(figure 5)

3. Race Sail Fitment (SailQube Race – SQR)

- a. Ensuring it is free of sharp objects that could damage the sail, spread the sail out on a large, clean, dry surface.
- b. Align the mast with the luff of the sail and the boom with the foot of the sail.
- c. Clip the boom gooseneck/claw clamp fitting to the mast immediately above/opposite the sprit halyard cleat.
- d. Making sure there is sufficient space for one finger to fit between the sail and the mast, secure the luff sail ties in place using a square knot in each.

(figure 8)

- e. Starting at the top of the mast, pass a corner tie through the upper eye-strap and through the top grommet in the luff of the sail.
- f. Pass the corner tie a second time around the eye strap and the grommet before securing it in place with a square knot.

(figure 9)

- g. Repeat this procedure for the lower eye-strap.
- h. Using two more corner ties and the same methodology, secure the tack of the sail around both the boom and the mast.

(figure 10)

- i. Be sure to adjust the corner ties in order to get the red mark on the luff of the sail to fit between the two blue stripes on the mast.

(figure 11)

- j. Making sure there is sufficient space for two fingers to fit between the sail and the boom, secure the foot sail ties in place using a square knot in each.

(figure 8)

- k. Pass the last remaining corner tie through the clew of the sail and around the boom.

- l. Pass the corner tie a second time around the clew and the boom before securing it in place with a square knot.



(figure 8)



(figure 9)



(figure 10)



(figure 11)

4. Boom Vang Fitment

Take the boom vang rope and tie a tight bowline loop around the boom immediately behind the boom vang peg. (Positioned on the upper surface of the boom approximately 300mm/1ft behind the gooseneck/claw clamp)

(figure 12)



(figure 12)

Thread the other end of the boom vang rope:

- Through the cleat on the lower aft face of the mast. (Travelling in an upward direction)
- Before tying a figure of eight stopper knot in the rope end.

(figure 13)



(figure 13)

5. Outhaul Fitment

Take the outhaul rope and tie a figure of eight stopper knot in one end.

Thread the other end of the outhaul rope:

- Through the boom outboard end cap fitting. (Travelling in a forward direction)
- Through the eye in the clew of the sail. (Travelling in a side to side direction)
- Through the boom outboard end cap fitting. (Travelling in an aft/rearward direction)

(figure 14)

- Through the cleat on the starboard/right side of the boom. (Travelling in a forward direction)
- Tie a 100mm/4" diameter bowline loop in the rope end to use as a handle or tie a figure of eight stopper knot.

(figure 15)



(figure 14)



(figure 15)

6. Mainsheet Bridle Fitment

Take one end of the boom bridle rope:

- Pass it twice around the boom ensuring that it is threaded through both the tiny bridle fairlead on the mid-upper surface of the boom and the 25mm/1" stainless steel ring on each pass.
- Tighten and tie the tail ends together using a square knot.

(figure 16)



(figure 16)

7. Stepping the Mast

- a. Point the bow of the boat directly in to the wind.
- b. Ensure the hull mounted adjustable mast step is adjusted to mid-range point.
- c. The adjustable mast step position should be tuned when your SailQube is fully rigged in order to facilitate the “ideal” being a horizontally aligned boom when sheeted in fully whilst going up-wind.
- d. Lift the mast with sail and boom attached.
- e. Align the mast heel over the hole in the SailQube deck plate.
- f. Gently slide the mast through the deck plate and carefully into the adjustable mast step.

(figure 17)

- g. Ensure the sprit halyard cleat is facing towards the bow and the vang cleat is facing towards the stern.
- h. If necessary twist the mast retainer elastic until taught when placed over the mast retainer peg. Place the mast retainer elastic over the mast retainer peg on the lower forward face of the mast. (In order to prevent the mast from sliding out of the mast cup in the event of capsize.)

(figure 18)



(figure 17)

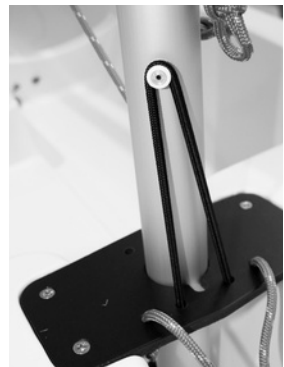

(figure 18)

8. Sprit Fitment

- a. Place one sprit end through the sprit loop at the head/top of the sail.
(figure 19)
- b. Place the other sprit end through the small bowline loop in the upper end of the sprit halyard.
(figure 20)
- c. Pull on the lower end of the sprit halyard to raise the top of the sail.
(figure 17)
- d. Cleat the sprit halyard at the point when the diagonal sail wrinkles disappear.



(figure 19)



(figure 20)

9. Rigging The 3:1 Mainsheet (SailQube School – SQS)

- a. Shackle the mainsheet fiddle/becket block with screw shackle on to the boom mounted stainless steel mainsheet bridle ring.
(figure 21)
- b. Clip the mainsheet fiddle/becket block with trigger shackle on to the hull mounted stainless steel main sheet fairlead.
- c. Tie one end of the mainsheet on to the fiddle/becket of the boom mounted block using a bowline loop.

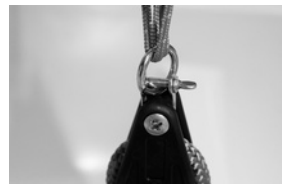

(figure 21)

Thread the other end of the mainsheet:

- d. Downwards and around the fiddle/becket of the hull mounted block. (Travelling in an aft/rearward direction)
- e. Upwards and around the main sheave/pulley of the boom mounted block. (Travelling in a forward direction)
- f. Downwards and around the main sheave/pulley of the hull mounted block. (Travelling in an aft/rearward direction)
(figure 22)
- g. Finally tie a figure of eight stopper knot in the end of the mainsheet to prevent accidental unthreading.

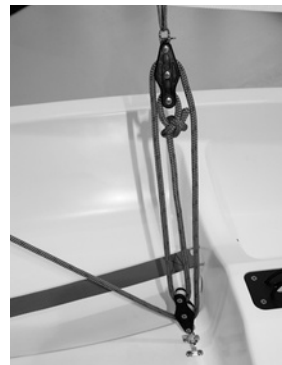

(figure 22)

10. 4:1 Mainsheet Ratchet Block Fitment (SailQube Race – SQR)

- a. Remove the white nylon counter sunk machine screws positioned immediately behind the stainless steel mainsheet fairlead on the hull.
- b. Where the nylon counter sunk machine screws were previously located - Attach the race specification stainless steel deck fairlead (2 hole) using the stainless steel M5x10mm pozi pan machine screws supplied.

(figure 23)

- c. Remove the shackle pin and ring from the mainsheet ratchet block. Loop the shackle beneath the aft deck fairlead (Just fitted) and place the compression spring over it.
- d. While compressing the spring, place the mainsheet ratchet block at the top of the spring and align the hole in the bottom of the block with the holes in the shackle.
- e. Secure the ratchet block to the shackle using the pin and ring.

(figure 24)



(figure 23)



(figure 24)

11. Rigging The 4:1 Mainsheet (SailQube Race – SQR)

- a. Shackle the mainsheet fiddle/becket block with screw shackle on to the hull mounted stainless steel mainsheet fairlead.

(figure 25)

- b. Clip the mainsheet fiddle/becket block with trigger shackle on to the boom mounted stainless steel mainsheet bridle ring.

(figure 26)

- c. Tie one end of the mainsheet on to the fiddle/becket of the hull mounted block using a bowline loop.

Thread the other end of the mainsheet:

- d. Upwards and around the fiddle/becket of the boom mounted block. (Travelling in an aft/rearward direction)
- e. Downwards and around the main sheave/pulley of the forward hull mounted block. (Travelling in a forward direction)
- f. Upwards and around the main sheave/pulley of the boom mounted block. (Travelling in an aft/rearward direction)
- g. Downwards and around the sheave/pulley of the hull mounted ratchet block. (Travelling in an aft/rearward direction)
- h. Ensure the ratchet block makes a ratchet like noise when pulling the tail on the mainsheet.
- i. If the block does not make a ratchet like noise, either the mainsheet is travelling through the ratchet block in the wrong direction or the ratchet switch is turned off.

(figure 27)

- j. Finally tie a figure of eight stopper knot in the end of the mainsheet to prevent accidental unthreading.

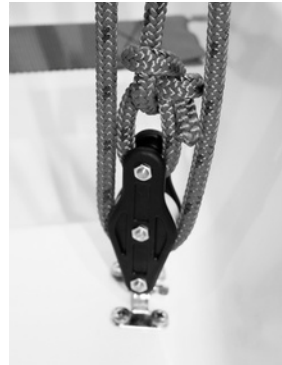

(figure 25)



(figure 26)



(figure 27)

12. Rigging The Painter

Take the painter rope and tie a tight bowline loop directly on to the rope loop in the centre of the mast deck plate bridle.

Thread the other end of the painter rope:

- a. Through the integral hull bow bush. (Travelling in a forward direction)
- b. Tie a figure of eight stopper knot in the rope end.
- c. Neatly coil up the painter rope until the figure of eight stopper knot touches the outer hull/bow surface.
- d. Place the neatly coiled up painter in the bow area of your SailQube ready for convenient deployment.

13. Rudder Assembly

- a. The tiller arm machine screws and washers should already be attached to the tiller arm.
- b. Remove these machine screws before aligning the two holes in the tiller arm with the two holes in the top of the rudder blade. (Ensure the tiller extension mounting bracket faces upwards.)

(figure 28)

- c. Screw the machine screws through the aligned holes before placing washers over each of the protruding threads.
 - d. Wind the nylon lock nuts on to the protruding threads carefully.
 - e. The lock nuts should be tightened until the tiller arm is secure but do not over tighten!
- (figure 29)
- f. Clip the tiller extension in to its mounting bracket on the uppermost forward surface of the tiller arm.



(figure 28)



(figure 29)

14. Rudder Fitment

- a. Align the pintle pins on the rudder above the gudgeon holes on your SailQubes transom.
- b. Push the rudder downward making sure the pintle/gudgeon sets and the rudder retaining clip engage correctly.
- c. To remove the rudder, press in the rudder retaining clip while lifting the rudder upwards.
(figure 30)
- d. Once the upper pintle clears the retaining clip the rudder will be released.



(figure 30)

15. Dagger-board Fitment

- a. Locate the hole in the handle of the dagger-board. This identifies the dagger-boards forward/leading edge.
- b. The forward/leading edge of the dagger-board should always be positioned closest to the bow when sailing.
- c. Only place the dagger-board into the dagger-board case when the boat is in the water.
(figure 31)
- d. The dagger-board should be lowered gradually as you sail into deeper water.
- e. The dagger-board deck plate elastics can be positioned to run around the dagger-board edges to add the friction required for accurate height adjustment whilst sailing.
- f. Alternatively they can simply be positioned to go over the dagger-board handle to hold it completely down.
(figure 32)
- g. **Always remember to raise the dagger-board when you sail in to shallower water or head back to the shore.**



(figure 31)



(figure 32)

16. Toe-Strap Configuration

Your SailQube toe-straps can easily be set to school or race mode by changing the rope configurations at the forward anchor points.

- Your SailQube is supplied with its toe-straps set to school mode.

(figure 33)

School mode supports the use of the toe-straps for the purpose of hiking but is configured so they are non-intrusive and hence comfortable whilst sitting on the cockpit floor when cruising.

- Alternatively your SailQube toe-straps can be set to race mode.

(figure 34)

- Race mode effectively elevates the forward end of both toe-straps for fast/reliable engagement whilst tacking and gybing during racing. Unfortunately this configuration is unavoidably more intrusive and hence less comfortable whilst sitting on the cockpit floor when cruising.

If you wish to set your SailQube toe-straps to race mode, change one side/anchor point at a time:

- a. Untie one of the two double overhand stopper knots. (Positioned on the forward face of the thwart)

(figure 35)

- b. Carefully unthread the anchor point rope until it is separate from both the toe-strap and your SailQube.

Thread the loose/tail end of the anchor point rope:

- c. Through the thwart in a forward direction.
- d. Over the thwart in an aft/rearward direction.
- e. Through the toe-strap in a side to side direction.
- f. Back through the thwart in an aft/rearward direction.
- g. Finally tie a double overhand stopper knot in the rope end.

(figure 36)

- h. Repeating this process on the second side/toe-strap

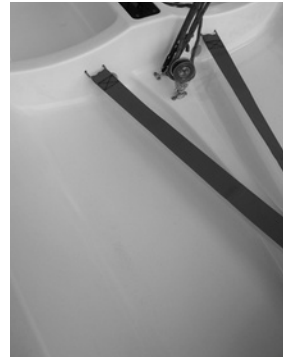

(figure 33)

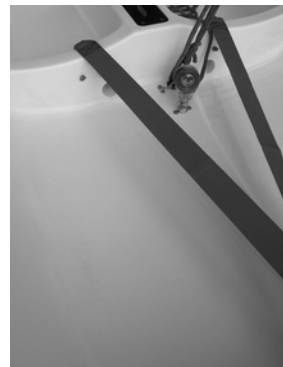

(figure 34)



(figure 35)



(figure 36)



17. Other Hints and Tips

- **In order to prevent boom disengagement from the mast** (caused by gybing when the vang is too loose): Tie a taught 4mm/1/8" x 300mm/12" rope around the mast and through the holes on either side of the gooseneck.
- **In order to cushion any potential boom-to-head contact:** Fasten a length of pipe insulation just aft of the boom bridle using electrical tape or cable ties.
- **In order to slow down the rate of complete inversion in the event of capsize:** Fasten a length of pipe insulation over the upper end of the sprit using electrical tape or cable ties.
- **In order to prevent the dagger-board from floating away in the event of disengagement from the dagger-board case when either sailing or capsized:** Tie a piece of 4mm/1/8" x 1300mm/52" line between the hole in the handle of the dagger-board and the hull of your SailQube.
- **In order to prevent the rudder from floating away in the event of disengagement from the gudgeon retaining clip when either sailing or capsized:** Tie a piece of 4mm/1/8" x 750mm/30" line between the base of the tiller arm and the hull of your SailQube.



7. Cleaning

- After sailing in salt water always rinse all SailQube parts using fresh water.
 - Sails should be thoroughly washed down with fresh water, dried and stored in a dry place.
 - For best results your SailQube **hull** should be cleaned using fresh water, washing up liquid, a sponge/cloth and a high pressure hose or power washer.
 - Do not use abrasive cleaners or scouring pads on any hull or component surfaces.
 - In corrosive atmospheres stainless parts may show discoloration/brown staining around screw holes and rivets over time, this is not serious and can be removed with a fine abrasive polish.
- Trailers and launching trollies should also be rinsed with fresh water.

•

8. Service

- Repairs to the polyethylene hull should only be undertaken by those with relevant skills and equipment. Contact your SailQube dealer for advice.
- Excess water should be removed from the hull.
- Ropes, rigging and fittings should be checked at regular intervals for wear and tear.
- All moving parts should be lightly lubricated to avoid jamming, i.e., McLube, Dry Teflon or a dry silicone based spray. Do not use oil.
- Inspect all shackles to ensure they are tight. (Pliers should be used for this operation).
- Damaged or worn parts should be replaced.
- It is recommended that trailers be serviced annually.
- Do not leave the rig under tension when not sailing or during storage.



9. Storage & Transport

- It is highly recommended that a trolley is used to launch and recover your SailQube.
- Dragging your SailQube up a beach or slip way will wear away the polyethylene and damage the boat.
- UV light will cause fading to some components and fittings, a waterproof/breathable cover is therefore highly recommended to reduce UV degradation.
 - Top covers must not be allowed to “flap” when driving at speed. This can abrade the surface of the hull and damage it.
- It is recommended if you are towing and plan to use your top cover that an under-cover is fitted first to prevent cover flap damage to the top sides of the hull.
- When securing your boat to a trailer for transport be very careful that ratchet straps and ropes are not over tightened and that there is sufficient padding under the strap or rope to prevent the hull/deck from being damaged through abrasion or pressure.
- Your SailQube hull should NOT be left on a pebble beach, as the polyethylene could dent.
- Care must be taken to support the hull adequately if storing on racking or in a similar manner.
- Any sustained point loading could permanently dent or distort the hull.
- Your boat should always be tied down securely to the ground when not in use.

10. On Water Towing

- Always use painter and transom bridle lines of 8mm/5/16” minimum diameter in order to prevent point load related damage to the integral SailQube bow and stern bushes.
- The inboard end of the painter should always be tied directly to the rope loop in the centre of the mast deck plate bridle when towing.
- Towing your SailQube at high speed (10 – 20 knots) behind a rib or power boat can seriously damage your SailQube and its component parts.
- The maximum recommended towing speed for your SailQube is 6 knots.

Enjoy Your SailQube Sailing!